



# OPERATION MANUAL

## GMF-LS01 300-WATT XENON FIBER OPTIC LIGHT SOURCE



# **TABLE OF CONTENTS**

<b>Section 1.0</b>	<b>INTRODUCTION</b>	<b>Page</b>
1.1	System Description	3
1.2	Receiving / Handling	3
1.3	System Inspection	4
<b>Section 2.0</b>	<b>TECHNICAL DATA</b>	
2.1	Specifications	5
2.2	Symbols	5-6
<b>Section 3.0</b>	<b>INSTALLATION</b>	
3.1	Assembly of the Mobile Floorstand with 360° Swivel	6-7
3.2	Rotary Turret Operation	7
3.3	Xenon Premium Fiberoptic Light Source Operation	8-9
<b>Section 4.0</b>	<b>MAINTENANCE</b>	
4.1	Repairs	9
4.2	Cleaning	9-10
4.3	Lamp Module Replacement	10-11
4.4	Input Voltage Auto-Switching	11
4.5	Resetting Elapsed Hour Meter	11
4.6	Xenon Lamp Replacement (Optional)	11-13
4.7	Repackaging and Environmental Storage Conditions	13
4.8	Service	13
4.9	Preventative Maintenance	13
<b>Section 5.0</b>	<b>CAUTIONS / WARNINGS</b>	<b>13-14</b>
5.1	Operating Cautions	14
5.2	Equipment Cautions	14
<b>Section 6.0</b>	<b>EQUIPMENT ORDER NUMBERS</b>	<b>15</b>
<b>Appendix A</b>	<b>Electrical Schematic, GMF-LS01</b>	<b>16</b>
<b>Appendix B</b>	<b>Gulf Fiberoptics Warranty Statement</b>	<b>17</b>

## 1.0 INTRODUCTION

### 1.1 System Description

The Gulf Fiberoptics **GMF-LS01 - 300 Watt Xenon** Fiber optic Light Source is a source of continuous high intensity daylight illumination for demanding surgical vision applications. This is a Class I device per CE MDD 93/42/EEC, Class I per UL 2601-1, and a Class II device per FDA regulations. Its mode of operation is continuous and its degree of electrical isolation is type "B".

The Xenon Fiber optic Light Source uses a 300-Watt Xenon Lamp that enables the unit to achieve a high intensity daylight (natural light) output as a result of the lamp's light collection efficiency.

The Gulf Fiberoptics **GMF-LS01 - 300 Watt Xenon** Fiber optic Light Source is intended to be used with Gulf Fiberoptics fiber optic cables for surgical headlamps and other lighted instruments that contain fiber optic bundles, and other fiber optic cables manufactured specifically for use with Xenon illumination systems. Consult your cable manufacturer or distributor to determine compatibility.

Illumination from this device is to be used for observation of body cavities, hollow organs and other surgical sites. This device is also intended for use as a light source for surgical headlights used in various surgical procedures.

This Fiber optic Light Source incorporates a graduated shutter that allows intensity control from 0 up to 100%. The Fiber optic Light Source automatically attains full output with a stable color temperature, natural daylight output, allowing automatic and manual video surgical procedures. The Xenon lamp light output is precisely focused to ensure maximum light transmission to the fiber optic cable.

The Xenon Fiber optic Light Source has a rotary indexing turret on the front panel that allows the Fiber optic Light Source to be used with ACMI/CIRCON, Olympus, Storz and Wolf type fiber optic cables for headlight adaptation.

This Fiber optic Light Source is also equipped with an elapsed lamp life indicator on the front panel which shows total hours elapsed. This indicates lamp replacement, avoiding a possible premature failure of lamp.

The Xenon Fiber optic Light Source is adaptable to a mobile floorstand with 360° swivel, as shown in Figure 1. Additionally, an optional Storage Compartment can be adapted to the Fiber optic Light Source, which can serve as a drawer for Headlight and cable, loupes and video camera control.

For operation, the Xenon Fiber optic Light Source requires connection to a 100-120V~ or 220-240V~, 50-60Hz line. The input voltage is automatically detected. See section 4.4 below. The Hospital Grade power cord provided by Gulf Fiberoptics must be used for connection to the power mains in the USA. Elsewhere, only an approved power cord (approved/rated for the country of destination) may be used.

### 1.2 Receiving / Handling

Inspect shipping container for evidence of shipping damage, preferably in the presence of the carrier. Noted damage should be reported to the carrier's agent.

Remove all packaging material from around the unit and carefully inspect for damage, which may have been caused by shipping.

### **1.3 System Inspection**

The Fiberoptic Light Source must be inspected before each use according to the procedure below.

1. Visually inspect the power cord, plug, intensity control and the fiber optic cable to assure there is no evidence of wear, damage or fraying.
2. Be sure that the fiber optic cable connector is clean and dry before plugging it into the rotary indexing turret.
3. Be sure that the rotary turret port to be used is aligned directly with arrow.

## 2.0 TECHNICAL DATA

### 2.1 Specifications

**Table 1. Optical**

Nominal Light Output (Initial Output)	>500,000 lux (at exit end of 5mm dia. x 7 ½ ft long fiber optic cable)
Lamp Life	600 Hours up to 1000 Hours

**Table 2. Electrical – Class I: Continuous BF**

Line Input Power	110-120vAC / 7.0 A Max <b>or</b> 220-240vAC / 3.5 A Max, 50/60Hz (Auto-detecting – see section 4.4)
Power Consumption	590 volt-amperes (Watts)

**Table 3. Environmental**





Operating Temperature	(+10° to + 40°C)
Storage Temperature	(+ 10° to + 40°C)
Operating Relative Humidity	30% to 75%
Storage Relative Humidity	10% to 75%
Operating Atmospheric Pressure	700hPa to 1060hPa
Storage Atmospheric Pressure	500hPa to 1060hPa
Enclosure Rating	IPX0 (not protected against ingress of liquids)

**Table 4. Physical (excluding fiber optics and power cable)**

Dimensions	5”H x 11”W x 12”D (12cm H x 28cm W x 30cm D)
Weight	14 lbs. (6.3 kg)
Space Requirements	Open to the rear to prevent recirculation of cooling air.

### 2.2 Symbols

	<p style="text-align: center;"><b>WARNING!</b></p> <p>The Xenon GMF-LS01 produces lethal voltages. Ensures that input power is disconnected before beginning any inspection or internal adjustment.</p> <p style="text-align: center;"><b>WARNUNG!</b></p> <p>Das Xenon GMF-LS01 erzeugt lebensgefährliche Spannungen. Es muss deshalb darauf geachtet werden, dass der ankommende Strom ausgeschaltet ist bevor Kontrollen oder Regelungen am Gerät unternommen werden!</p> <p style="text-align: center;"><b>ATTENTION!</b></p> <p>Le Xenon GMF-LS01 fournit des tensions dangereuses. Veuillez vérifier que la prise de courant est déconnectée avant d'entreprendre des inspections ou des réglages sur l'appareil.</p>
---	---

	<p style="text-align: center;"><b>ATTENTION!</b></p> <p>This symbol notifies the user to consult the accompanying documents.</p>
	<p style="text-align: center;"><b>ATTENTION!</b></p> <p>This symbol signifies that the surface(s) near where the symbol is placed are hot and may require thermal protection when touching the surface(s).</p>
	<p style="text-align: center;"><b>ATTENTION!</b></p> <p>This symbol identifies that the system is a Type B Applied Part.</p>
	<p style="text-align: center;"><b>ATTENTION!</b></p> <p>This symbol signifies that light intensity will increase when the knob is turned in a clockwise motion and decrease when the motion is counter-clockwise.</p>
	<p style="text-align: center;"><b>WARNING!</b></p> <p>Any component with this label will be hot after operation.</p> <p style="text-align: center;"><b>DO NOT TOUCH!</b></p>

### 3.0 INSTALLATION

#### 3.1 Assembly of Optional Mobile Floor Stand with 360° Swivel Base

The following instructions describe the assembly of the optional 30" mobile floor stand and swivel base. The 30 inch mobile floor stand consists of four (4) parts:

- One (1) Five Legged Base with 2 locking and 3 rolling/non-locking Casters
- One (1) Lower Column
- One (1) Upper Column (with Plastic Bushing)
- One (1) 360° rotating, 5° tilted up Swivel with two (2) Headlight / Power Cord Hangers

Please follow the steps below in order to complete the assembly of the 30 inch floor stand to the 300 Watt Xenon Fiberoptic Light Source (reference Figure 2):

- 1) Place the Five Legged Base with Casters on the floor.
- 2) Slide the tapered end of the lower column into the center hole of the five (5) legged base.
- 3) Slide the upper column into the lower column. The plastic bushing must point up when assembled.
- 4) Place the Fiberoptic Light Source upside down on a soft cloth or plastic and remove the four- (4) knobs. The four (4) studs should face up.
- 5) Place the Swivel on the Fiberoptic Light Source above, so that the four (4) studs protrude through the slots of the swivel. Please note that the arrow on the swivel indicates the front, to assure that the 5° tilt is positioned to the front panel of the Xenon Fiberoptic Light Source.
- 6) Tighten the four (4) knobs on the studs and make sure that the swivel and Fiberoptic Light Source assembly are securely held together.
- 7) Turn the above assembly over and place the swivel column into the assembled base with casters.

Please follow steps 1 through 7 above in order to complete the assembly of the 22 inch floor stand to the 300 Watt Xenon Fiberoptic Light Source/ Storage Module Assembly:

Note: Steps 2 and 3 will become one step, since there is only one (1) 22" column tapered on one end and with plastic bushing on the other end.



*Figure 2*

### **3.2 Rotary Turret Operation**

The Gulf Fiberoptics **GMF-LS01 - 300 Watt Xenon** Universal Fiberoptic Light Source is equipped with a low profile, non-conductive, indexing rotary turret allowing the adaptation and use of a wide range of fiber optic cables, such as: ACMI / CIRCON, OLYMPUS, STORZ and WOLF.

To select your port of choice, simply rotate the turret 360° in both directions until the desired adaptation port lines up with your fiber optic cable. Insert the fiber optic cable into the light output port. Verify that the cable is fully inserted and snaps in position.

### 3.3 Xenon Fiberoptic Light Source Operation

**CAUTION!** Allow enough time for the unit to reach the minimum operating temperature of +10°C (50°F) before turning the power switch ON.

#### **ELECTRICAL SHOCK HAZARD**

Do not open the enclosure, except to replace the lamp module, as indicated in Section 4.3.

1. Insert a compatible, clean and dry fiber optic cable connector into the turret by indexing the turret to the adaptation of your choice, such as Acmi / Circon (standard), Olympus (Japan), Storz or Wolf (Germany).

#### **RISK OF ELECTRICAL SHOCK**

Do not use electrically conductive fiber optic cables or any fiber optic cables using steel monocoil protective tubing

2. Turn the manual variable intensity control knob counterclockwise to the lowest position.
3. Plug the power cord into a properly grounded electrical socket, utilizing a hospital approved safety cord.

#### **GROUNDING RELIABILITY**

Grounding Reliability can only be achieved when the equipment is connected to an equivalent receptacle marked "Hospital Only" or "Hospital Grade".

#### **MAINS DISCONNECTION**

The appliance inlet located on the rear panel of the enclosure, where the detachable power cord is plugged into, serves as the designated Mains disconnection device.

4. Verify that the air vents are not blocked, assuring proper cooling.
5. To turn the Fiberoptic Light Source on, press the main power switch to the ON position. The Fiberoptic Light Source does not require warm-up time before use.

**Note: It is normal for the power supply to strike an arc in the lamp several times (an audible clicking sound will be heard) before the lamp lights.**

6. Adjust the light intensity by turning the knob clockwise until the desired daylight brightness is achieved.

#### **WARNING!**

Avoid looking directly at the high intensity light, whether at the unit itself or at the end of the fiber-optic cable, as this can result in damage to the eyes.

7. When procedure is completed, turn the manual intensity control knob counterclockwise to the lowest setting. Then, turn the power switch of the Fiberoptic Light Source in the OFF position and disconnect the fiber optic cable.



8. Disconnect the power cord from the back panel-mounting receptacle if the Xenon Fiberoptic Light Source is not going to be used for a period of time.

**WARNING!**

It is essential that the operating specifications and parameters described in Gulf Fiberoptics literature and those accompanying other manufacturer's components be observed and not be exceeded under any conditions. Please observe warnings on the Xenon Fiberoptic Light Source's cover. To install or operate this system in a manner for which it is not intended may cause personal injury, as well as severe damage to the product and/or other systems.

**WARNING – POSSIBLE ELECTRO-MAGNETIC OR OTHER INTERFERENCE**

This equipment generates, uses and can radiate radio frequency energy and, if not installed and used in accordance with the instructions, may cause harmful interference to other devices in the vicinity. However, there is no guarantee that interference will not occur in a particular installation.

If this equipment does cause harmful interference to other devices, which can be determined by turning the equipment on and off, the user is encouraged to try to correct the interference by one or more of the following methods:

- Reorient or relocate the receiving device
- Increase the separation between the equipment
- Connect the equipment into an outlet on a circuit different from that to which the other device(s) are connected.
- Consult the manufacturer or field service technician for help.

## 4.0 MAINTENANCE

### 4.1 Repairs

The **GMF-LS01 – 300 Watt Xenon** Fiberoptic Light Source has no user serviceable parts. See Section 4.7 in this manual for preventative maintenance.

**WARNING!**

Routinely examine hospital approved power cord provided by Gulf Fiberoptics Do not use if it reveals damage.

In the event that the unit fails or does not function properly (other than lamp failure), it is strongly suggested that no attempt be made to troubleshoot. Field repairs and customer modifications are not authorized and, if attempted, will void the warranty and could void product certification. Repairs must be made only by factory-authorized personnel.

### 4.2 Cleaning

Before attempting any maintenance or cleaning of the Fiberoptic Light Source, be sure that the Fiberoptic

Light Source is unplugged and it is cooled off.

The Xenon 300 Fiberoptic Light Source may be cleaned by use of a cloth dampened with a mixture of 70%-denatured alcohol and 30% water. This equipment is rated IPXO, ordinary protection against harmful ingress of liquids. Do not pour liquids on the cabinet!

### 4.3 Lamp Module Replacement

**Warning:** Disconnect the main power line before attempting any service to the Xenon lamp.

Xenon lamp replacement is recommended after 600 hours of operation time. Failure to do so may result in insufficient or failure of illumination. It is recommended that a spare Xenon lamp module be kept on hand in case of failure.

	<p style="text-align: center;"><b>WARNING!</b></p> <p>Xenon Lamp Replacement to be done by authorized personnel only.</p>
---	---

<p style="text-align: center;"><b>WARNING!</b></p> <p>Xenon lamp is a high-pressure, gas-filled device. Wear safety glasses when replacing the module or the Xenon lamp.</p>
--

1. Put the power switch to the OFF (0) position and disconnect the power cord.

	<p style="text-align: center;"><b>WARNING!</b></p> <p>The <b>GMF-LS01 – 300 Watt Xenon Fiberoptic Light Source</b> may produce hazardous leakage voltages. Ensure that input power cord is disconnected before starting any inspection or internal adjustment.</p>
---	--

2. Remove the cover by removing the six (6) screws on the side of the unit. Use Phillips screwdriver (see figure 1). Lift cover to remove.

<p style="text-align: center;"><b>WARNING!</b></p> <p>Parts inside the <b>GMF-LS01 – 300 Watt Xenon Fiberoptic Light Source</b> may exceed 70°C and could create a burn hazard. Allow 20 minutes for cooling down.</p>
--

3. Remove the screw and clamp that secure the lamp module to its platform. (see figure 2)
4. Carefully slide the Xenon lamp module out of the unit. The complete lamp module can be returned for replacement. For on-site replacement of the Xenon lamp, proceed to Step 2 of Section 4.5 below.

<p style="text-align: center;"><b>WARNING!</b></p> <p>Removing the lamp module exposes high voltage connectors. <b>DO NOT TOUCH THE HIGH VOLTAGE CONNECTORS!</b></p>
--

5. Unpack a new lamp module, and then install it by pressing the electrical connectors into the banana jacks in the unit.

6. Attach the lamp module clamp and tighten the screw to secure the lamp module to the lamp module platform.
7. After completing a lamp replacement or lamp module replacement, reset the digital hour meter located on the front panel. (see Section 4.5 below)

#### 4.4 Input Voltage Auto-Switching

1. The power supply of either 110-120 VAC or 220-240 VAC is acceptable. The unit will auto-detect the input voltage.

#### 4.5 Resetting Elapsed Hour Meter

1. Remove the top protective cover from the light source by removing the six screws on the side of the unit. There are three on each side.
2. Locate the hour meter timer connections. Find the wire connection to the junction on the timer labeled "I" (red junction on the bottom). Move this connection to the junction terminal labeled "R".
3. Turn ON unit for a few seconds until hour meter timer displays "0.0".
4. Turn OFF unit.
5. Remove the red wire from the "R" terminal and place it back on its original junction terminal "I".
6. Secure the protective cover back in place using the six screws.

#### 4.6 Xenon Lamp Replacement (Optional)

**WARNING!**

The Xenon lamp is a high-pressure, gas-filled device. Wear safety glasses when replacing the module.

1. Remove the Xenon lamp module from the system by performing steps 1 through 4 of Section 4.3 above.

**WARNING!**

When removing the **GMF-LS01 – 300 Watt Xenon** lamp module, parts may exceed 70°C and could create a burn hazard.

2. Remove the screw terminals that make the electrical connection to the unit. This also releases the lamp heatsink assembly from the lamp module housing.
3. Slide the lamp heatsink assembly out of the plastic housing.
4. Remove the screws from both heatsinks by gently unscrewing with a screwdriver, and then slide the heatsinks off the lamp. Remove the cooling ring from the cathode (window) side of the lamp.
5. Remove the defective Xenon lamp and set aside.

6. Carefully remove the new lamp from its shipping container.
7. Apply a light coat of the thermal compound (supplied with the lamp) on the collar (anode side +) of the lamp. See Figure 3. Insert the lamp into the anode heatsink, line up with hole pattern on heat sink and gently tighten the three (3) screws until fully seated to secure heatsink to lamp.
7. Apply a light coat of the thermal compound (supplied with the lamp) on the collar (cathode side -) of the lamp. Insert the cooling ring into the collar (cathode side -) of the lamp. Apply a very thin coat of thermal compound to the collar and outside of the cooling ring. See Figure 3.

**WARNING!**

Avoid placing thermal compound on the ceramic body or the sapphire window. Should thermal compound or fingerprints appear on the window, remove with alcohol and a cotton swab.

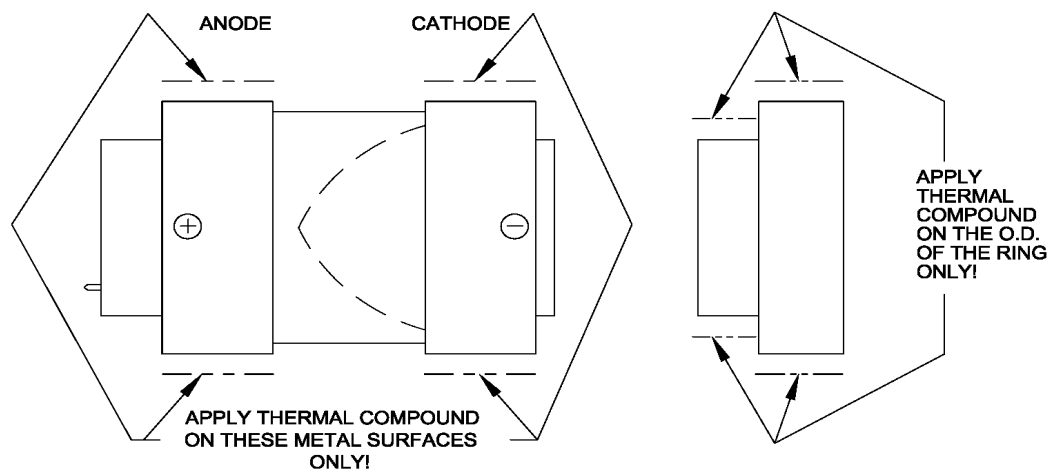

**Fig 3. Thermal Compound Application**

8. Insert the lamp and anode heatsink assembly into the cathode heatsink. Rotate heatsink to align the positive (+) and negative (-) electrode (threaded) holes in the heatsink. Gently tighten using the two (2) screws. Do not over tighten!
9. Slide the heatsink assembly into the plastic housing making sure that the heatsink electrical connection holes line up with the corresponding holes in the plastic housing. Make sure that the reflector faces front of plastic housing.
10. Install the lamp connections by tightening the two connectors into the top of the lamp assembly plastic housing. The 10-32 thread goes on the anode section and the 8-32 thread goes on the cathode section. Hand tighten.

**WARNING!**

The lamp contains xenon gas at high pressure. Proper disposal procedures must be followed. Use eye protection when working with Xenon lamps.

Note: The old Xenon lamp may be rendered harmless by opening the pinched off tubulation located on the back of the lamp. This may be accomplished by cutting it with a pair of diagonal cutters. Once

this has been done, the old lamp may be discarded with normal trash. If this is not done, the lamp should be repackaged in its original carton, and returned for disposal. Complete unit should be disposed of in accordance with applicable federal, state and local regulations.

11. Complete the installation by performing steps 6 and 7 of Section 4.3 and Section 4.4.

#### **4.7 Repacking and Environmental Storage Conditions**

If the Gulf Fiberoptics **GMF-LS01 – 300 Watt Xenon** Fiberoptic Light Source is to be stored for a prolonged period, shipped to another location, or returned to the factory for repair, repack it in the original packaging material. If this material has been discarded, pack the unit so as to prevent movement within the container and damage from improper handling. A storage area should have a relative humidity of 10% to 75% and an ambient temperature range of +10°C to +40°C (50°F to 104°F).

#### **4.8 Service**

Contact Customer Service at Gulf Fiberoptics by telephone at: +1 813.855.6618 or by e-mail at [contact@gulffiberoptics.com](mailto:contact@gulffiberoptics.com).

#### **4.9 Preventative Maintenance**

The following operations should be done every six months:

1. Remove the cover as explained in 4.3., item 2.
2. Inspect the inside of light source for any dirt, lint or other foreign material. Remove carefully with a hand vacuum.
3. Inspect the heat filter and focussing lens for accumulation of dirt or dust. If accumulation is evident, remove material with an alcohol saturated swab.
4. Check if all the mechanical components are tightened in place. Retighten if necessary.
5. Replace the cover as explained in 4.3, item 8.

#### **5.0 CAUTIONS / WARNINGS**

- To ensure safety, this manual must be read and understood in its entirety before using the Gulf Fiberoptics **GMF-LS01 – 300 Watt Xenon** Fiber Optic Fiberoptic Light Source.
- The Fiberoptic Light Source must not be used in the presence of flammable anesthetics due to the danger of explosion.
- **Danger:** Do not look directly at the Xenon lamp. The light produces high intensity visual and ultraviolet radiation that may burn the skin or eyes. The Fiberoptic Light Source must never be used in procedures requiring direct illumination of the eye (s).
- Do not block air vents. Adequate cooling is required for proper operation of the unit.
- Fiber optic cables must be thoroughly cleaned and completely dried before plugging into the Premium Fiberoptic Light Source housing.
- Ground reliability is achieved only when the Fiberoptic Light Source is connected to a "Hospital-Use"

or “Hospital-Grade” receptacle. Inspect electrical plug or cord routinely. Do not use if damage is discovered.

- The lamp in this unit is filled with Xenon at very high pressure. It will fracture with careless handling. Do not subject the lamp to high mechanical forces or rough handling that may fracture the lamp.
- Due to the high internal voltage of the power supply, a hazard exists for electrical shock. Always unplug the Fiberoptic Light Source prior to servicing the lamp.
- Disconnect the main power line before attempting any service to lamp cartridge or lamp.

### **5.1 Operating Cautions**

- Do not switch power ON-OFF-ON-OFF. Wait sixty (60) seconds in between to discharge internal high voltages to avoid possible damage to high voltage power supply. Minimize the number of lamp start-ups. Use lamp intensity position as a “standby” instead of turning off the power in between surgical procedure intermissions.

- Do not use this Xenon fiber optic Fiberoptic Light Source in the presence of flammable substances.

**Danger** - The distal connector of the fiber optic cable can cause burns. Do not place on protective drapes or on the patient.

- The Xenon Fiberoptic Light Source can cause permanent eye damage if light output is viewed directly with unprotected eyes.

### **5.2 Equipment Cautions**

- The Xenon Fiberoptic Light Source may cause failure and possible burning of fiber optic cables that are not designed for use with the Xenon Fiberoptic Light Sources. Consult your cable manufacturer or distributor to determine compatibility.
- Read this manual before removing the cover of the Fiberoptic Light Source.
- Keep cooling vents free from obstruction.
- Do not operate unit with front panel facing upward.
- This unit should not be used or stored where water or other liquids may splash.
- Avoid operating the unit in dusty or dirty environments. Dirt entering the air intake will shorten the life of the lamp.

## **6.0 EQUIPMENT ORDER NUMBER**

**GMF-LS01 - 300 Watt Xenon** Fiberoptic Light Source

**GMF-LSST – Mobile Floor Stand**

:

**GMF-H100 – Fiber Optic Headlight** with 9ft bifurcated cable, Wolf light source connector:

**To obtain additional replacement parts not listed above, please contact Customer Service at Gulf Fiberoptics by e-mail at [contact@gulffiberoptics.com](mailto:contact@gulffiberoptics.com).**

## **CONTACT INFORMATION**

**Gulf Fiberoptics, Inc.**

448 Commerce Blvd.

Oldsmar, Florida 34677

U.S.A.

Telephone: +1 813.855.6618

Facsimile: +1 813.855.6627

E-mail: [contact@gulffiberoptics.com](mailto:contact@gulffiberoptics.com)

Website: [www.gulffiberoptics.com](http://www.gulffiberoptics.com)

# Appendix A – Electrical Schematic, GMF-LS01

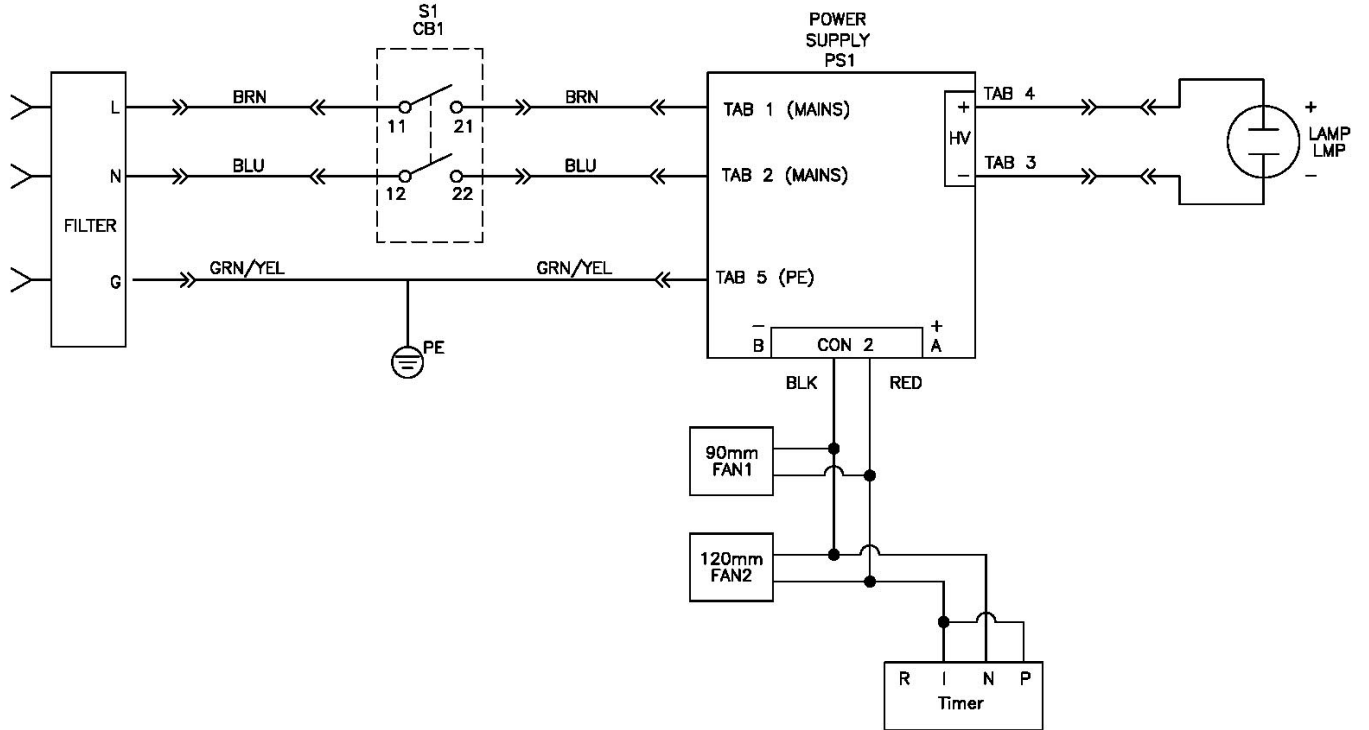



## Appendix B

### Gulf Fiberoptics Warranty Statement

Xenon "Mobile" and "Portable" Illumination systems mechanical parts are warranted for a total of one (1) year from the casters to the cover of the xenon illuminator.

Xenon "lamps" are warranted for a total of five hundred (500) elapsed hours. The supplier of the xenon lamp will determine the pro-rated refund against the purchase of a new lamp. Allow four to six weeks for a reply.

Xenon "power supplies" are warranted for a total of one (1) year.

Fiber optic bifurcated headlight cables are warranted for a period of one (1) year against defects in material and workmanship. We reserve the right to pass judgment on the cause of defect. Misuse and breakage of the fibers by the end user may invalidate the warranty.

Headlight modules and headgear are warranted for a total of one (1) year.

Warranties are void if service is performed by unauthorized persons.

Warranties are not transferable, unless authorized in writing by Gulf Fiberoptics.

Warranties are null and void due to accidental dropping of the xenon illuminator(s) and headlight(s).

Warranties are to be processed within a period of approximately 10-20 working days, excluding holidays.

Gulf Fiberoptics reserves the right to pass judgment on any and all warranties of product(s) abused or mishandled, including full or partial disassembled.

Gulf Fiberoptics reserves the right to modify the above warranty statement with 60 days notice.